

Self-scalable Fuzzy ArtMap for Received Signal Strength Based Location Systems

Uzair Ahmad, Andrey Gavrilov, Young-Koo Lee, and Sungyoung Lee

Department of Computer Engineering
Kyung Hee University, Republic of Korea
{uzair,avg,yklee,sylee}@oslab.khu.ac.kr

Abstract. Location systems have several demanding applications particularly in indoor environments but require costly infrastructure of sensors. Received Signal Strength based positioning provides economical viability to enabling these applications. Although extensive research has been carried out in this area still tedious implementation and lengthy development life cycle prohibit wide scale adoption of this technology. We present a new approach based on Fuzzy ArtTMap neural network that significantly reduces development time. Besides shortening development time of location systems this approach shows competitive accuracy and allows dynamic expansion of location aware site.

Key words: Online Learning, Received Signal Strength, Positioning Systems, Location aware computing

1 Introduction

Positioning systems are on the verge of becoming common services in modern mobile and ubiquitous computing spaces [7],[8],[11]. Satellite signal based GPS technology globally provides pervasive location awareness but suffers from degraded accuracy in indoor environments. Indoor positioning systems have been subject to costly infrastructure and special hardware devices mounted on the objects of interest Active Badge [12],Cricket [15],Active Bat [14] and Ubisense [13]. Received Signal Strength based positioning technology offers viable solution to ever increasing users of hand held devices, e.g. PDAs and note books connected through pervasive deployments of Wireless LAN infrastructure. Since signal strength measurements must be reported by the wireless network interface card ,built into these devices, as part of standard compliance positioning using received signal strength (RSS) is both feasible and economical. [6],[9], [10],[16],[18], [19]. RSS based location awareness applications include, but not limited to, a wide range of services to the end user like automatic call forwarding to user's location, robotic global localization, exploration and navigation tasks, Finder, Guiding and Escorting systems, first hop communication partners, liaison applications, location based advertisement and positioning of entities in large warehouses. Basic concept behind WiFi RSS based location awareness is that received signal strengths, from different Access Points (APs), follow certain patterns, so

called fingerprints, at a particular location. These patterns are captured at each location and stored in a database namely "Radio Map". Later when some device reports the same pattern, it is matched with previously captured patterns and location of that device can be estimated. Process of capturing the RSS at particular locations in a site is called 'site calibration'. Fig 1 shows the methodology of calibration process. RSS based location estimation is classification problem in the sense that location of device is estimated based on RSS feature vectors received by the target machine. Fundamental assumption behind such systems is that RSS values exhibit distinguishable features at different locations. These patterns are collected, in site calibration phase, and stored in Radio Map feature space as shown in Fig. 1. Radio Map plays pivotal role of training pattern classification machines which are then used to estimation location on the basis of received signal strength patterns reported by mobile devices.

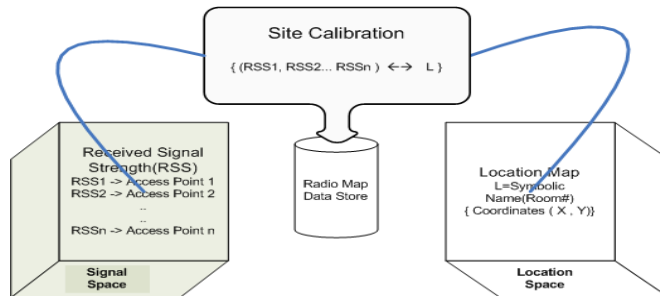

Fig. 1. RSS Based Location Estimation

2 Related Work

Received Signal Strength based location estimation has acquired a lot of interest from research community. Nearest Neighbors based pattern recognition technique and its derivatives have been used by pioneering works on RSS based location estimation for example RADAR [6] and [9]. Nearest Neighbor and its variants require a database of sample RSS, so called Radio map, readings at the estimation time for pattern matching. As the area and number of target locations grow, size of this database dramatically increases and face with scalability issues.

Some researches have also employed GPS like triangulation method for location estimation with lower accuracy than other methods. Asim et al [17] achieved 4.5 meter location estimation error in area of 60 square meters target. Triangulation methods work on assumption that signal strength decays only as function of distance of receiver device from sender access points. Radio Signal strength decay is function of several factors of indoor environments that affect the validity

of this assumption. This fact severely limits the accuracy of such methods for indoor location estimation.

Probabilistic approaches like bayesian networks based solutions have also been employed for this problem but are computationally exhaustive and difficult to scale. Andrew et al [10] reported 1.5 square meter distance error but only for 30 square meter area test bed. As the area and number of target locations and wireless access points increase, the complexity of Bayesian structures grows and become computationally expensive.

Neural network have been widely employed in pattern recognition problems due to their remarkable ability to tolerate noise and to generalize to patterns unseen at training time. Ogawa et al employed Learning Vector Quantization networks to develop location estimation system for 350 square meter area using 5 access points[16]. Battiti et al have reported their research on using feed forward back propagation network on small scale (624 square meter area using 3 access points) location estimation system [18]. A 'Modular Multi Layer Perceptron' approach is presented in [19] that improves accuracy and scalability of RSS based location estimation.

3 Fuzzy ArtMap based Location System

In this paper we present a location system based on self-scalable Fuzzy ArtMap. Fuzzy ArtMap is more general ArtMap (also called Predictive Art) network which can handle analog input patterns and performs online incremental supervised learning of pattern-class pairs presented in arbitrary order. Compared to previous work our location system offers several desirable features which cannot be realized using previous methods.

Rapid Development of RSS based location systems is major issue that keeps this technology from becoming widely deployed. Unlike previous systems, this approach requires no off line training (or lab time) to train classifier. Fuzzy ArtMap can learn pattern-class pairs online in real time. Online learning of RSS patterns and corresponding locations enables rapid location system development. Fig. 2 (left) shows schematic of development life cycle in off line training based systems. By virtue of online learning capability of Fuzzy ArtMap this approach removes site calibration phase and off line training phase from development life cycle, as shown in Fig. 2 (right), and realize rapid location system development.

Flexible and Dynamic expansion of location system is easy and straight forward in our approach. By expanding location system flexibly and dynamically we mean incrementally learning new location in real time thus increasing area by including more target locations. In order to achieve this purpose, using previous approaches, Radio Map feature space is required to be extended to include training RSS pattern-location mapping and then retraining of classifier with extended radio map. In case of retraining with new feature space, most of 'off line training' based classifiers face with the 'Stability plasticity dilemma'. That means learning new pattern-class mappings causes erosion of previous knowledge acquired by classifier during early training. Other techniques overcome this problem by

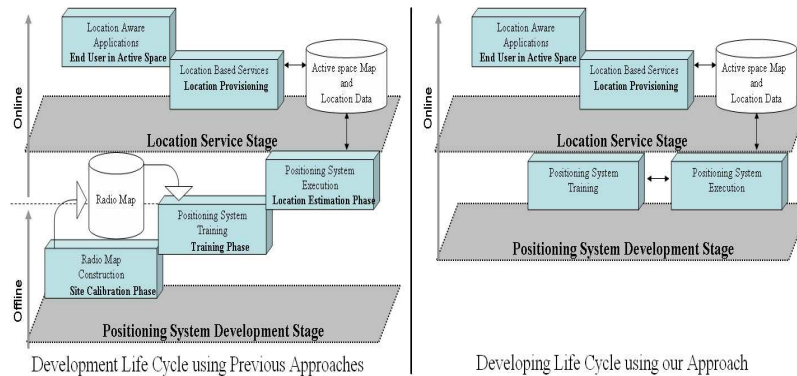

Fig. 2. Development Life Cycle of our location system

retraining classifier with whole Radio Map (that includes both old and new training data). Fuzzy ArtMap is capable of incremental learning and ensures stable learning of categories while exposed to new set of pattern-class pairs [4]. This capability allows flexible learning of new locations without requiring retraining with whole new feature space.

Learning Rare Events is very common issue that RSS based location classifiers face. Very nature of radio wave propagation in indoor environments cause imbalanced classes. It means that there may be some locations where size of RSS training patterns is far less than other locations. Fuzzy ArtMap is capable of learning based on a single exposure to an event, and does not show the catastrophic forgetting of rare events that other classification methods do. Moreover inside the building radio wave propagation follows a complex model and produce non stationary feature values in RSS vectors. Fuzzy ArtMap exhibits remarkable ability to classify non stationary data sequences.

4 System Design and Implementation

We conducted our experiments in 1200 square meter area of Computer Engineering Department Building as shown in Fig. 3. In this section we briefly explain basics of Fuzzy ArtMap network and how it is applied to location estimation problem.

Fuzzy ArtMap is Adaptive Resonance Theory (ART) based Self organizing neural network for real time autonomous learning environments. Fuzzy ArtMap network is composed of a pair of Fuzzy ART networks (Fuzzy ART_a and Fuzzy ART_b) which employ combination of fuzzy logic and Adaptive Resonance Theory [?] to establish stable recognition categories in response to temporal stream of analog RSS input patterns. Rigorous characterization of Fuzzy ART and Fuzzy

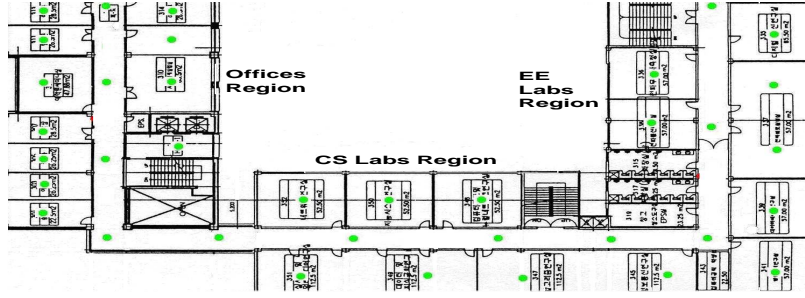

Fig. 3. Target Site

ArtMap neural networks can be found in [2] and [3]. Fig. 4 shows schematic structure of Fuzzy ArtMap neural network. Fuzzy ART modules ART_a and

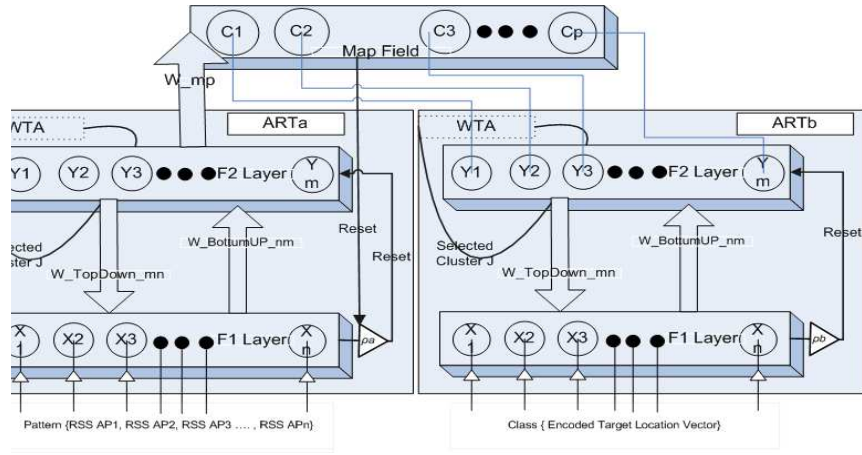

Fig. 4. Fuzzy ArtMap Schematic

ART_b self-organize category grouping for separate input sets v (feature RSS vector reported by mobile device) and e (encoded location information). Map Field is inter-ART module that controls the learning of an associative map from ART_a recognition categories to ART_b recognition categories. This is achieved by connecting F_2 Layer, so called F_2^b , neurons of ART_b to Map Field nodes with on-to-one, non-adaptive links in both ways. On the other hand each F_2 layer, so called F_2^a , neuron of ART_a is connected to all Map Field nodes via adaptive links. Since Map Field represents a mapping from both F_2^a and F_2^b it is referred to as F^{ab} . This map does not directly associate feature vectors with encoded class labels but rather associate the compressed codes of groups of v and e . During learning pattern-class pairs, if a mismatch occurs at Map Field

between ART_a category and ART_b category then system increases vigilance parameter of ART_a so that ART_a can categorize this pattern in different category or can create new category for this pattern that matches ART_b class category. This mechanism allows network to capture novel features that can be incorporated through learning new ART_a recognition category. Activation of Map Field results in output signal from each F^{ab} node, a vector corresponding to target location, that eventually becomes out put of Fuzzy ArtMap network. Learning RSS-location pair occurs if Fuzzy ArtMap network is presented with both RSS input vector and target location vector. In Location estimation occurs in case only RSS input vector is presented to network. Activation of F^{ab} occurs both in case of learning mode and estimation modes. Match tracking and orienting subsystem allows Fuzzy ArtMap network to establish different categories for similar RSS inputs at ART_a and also allow very different RSS inputs to form categories that make same location estimation. This is achieved by activating orienting subsystem only when ART_a makes a location estimate that does not confirm with actual location provided to ART_b . This condition starts match tracking by adjusting ART_a vigilance parameter in such a way that estimation error is removed.

4.1 Fuzzy ArtMap Implementation

We adapt a simplified version of Fuzzy ArtMap, presented in [5], which employs only one Fuzzy Art network instead of two with same learning and recall performance as original Fuzzy ArtMap. Simplified architecture is optimized for hardware implementation of Fuzzy ArtMap network. The learning dynamics of this network are shown in Fig. 5 (right). Fig. 5 (left) shows learning algorithm dynamics of general Fuzzy Art. Original Fuzzy ArtMap specification requires that capacity of network, in terms of number of categories (locations in our case) that network can learn, need to be fixed prior to learning. Prior fixation, of number of categories that network can learn, means that once RSS patterns of a 'fixed' number of locations (with respect to the capacity of network) are learned by network, then more locations cannot be learned (or incorporated) into that network. This limits the application of original Fuzzy ArtMap in terms of dynamically expanding the location system. We adapt original Fuzzy ArtMap in our implementation such that it do not require capacity of network to be fixed prior to learning and allows network to self-scale itself as new categories (locations) are presented to it. Our implementation of our self-scalable fuzzy ArtMap network is available as open source [20]. Learning dynamics of self-scalable Fuzzy ArtMap are shown in Fig. 6.

4.2 RSS Inputs and Target Location Encoding

Inputs are presented as predefined ordered sequence of received signal strengths of a set of access points deployed in target area. Fuzzy ArtMap network suffers from category proliferation problem as characterized by Moore [1]. In order to overcome this problem a normalization technique, namely Complement Coding,

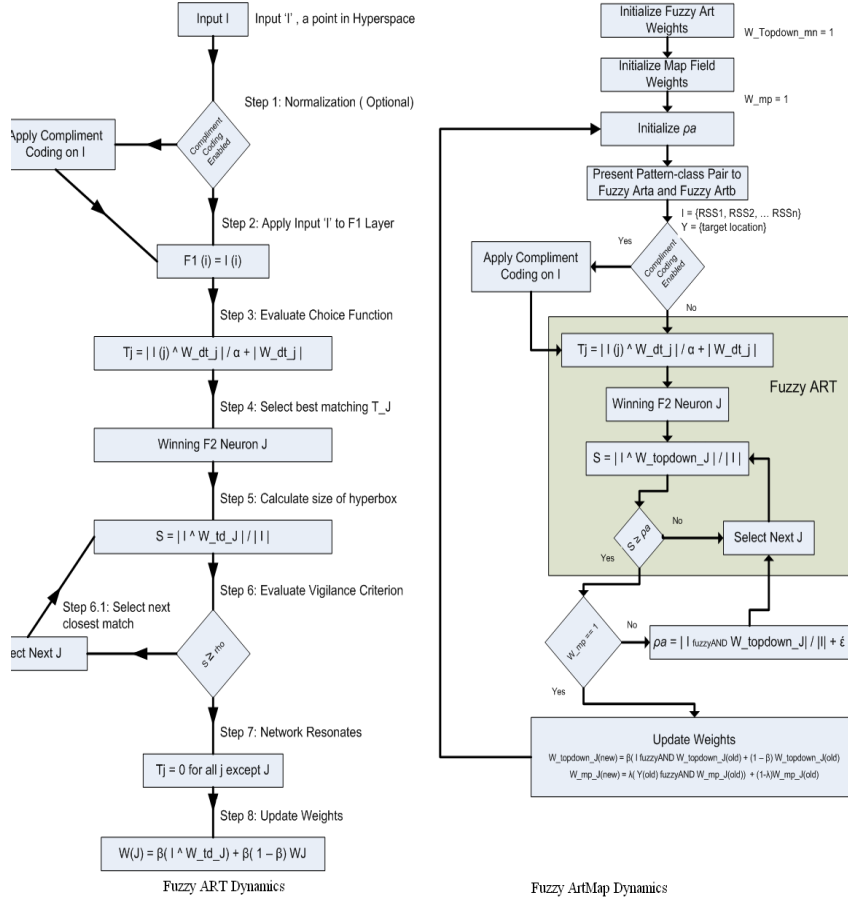

Fig. 5. FuzzyART Learning Process(Left) Fuzzy ArtMap Learning (Right)

is proposed by Carpenter et al in [2]. This normalization technique allows network to reduce effect of presentation frequency of an input pattern and order of presenting input patterns as explained in [3]. Since our aim is to develop location estimation system without off line training, complement coding enables fast online learning of RSS pattern and corresponding location pairs. Therefore we apply complement coding normalization to RSS patterns at learning and estimation time. Complement coding requires input pattern values to be in range of 0 to 1 but actual RSS values range between -10 dBm to -100 dBm. We apply scaling normalization on raw RSS input vector such that all values are transformed in range of 0 to 1.

Target locations are represented as ID (a number that uniquely identifies a location from others). Inside network target locations are represented as binary encoded form.

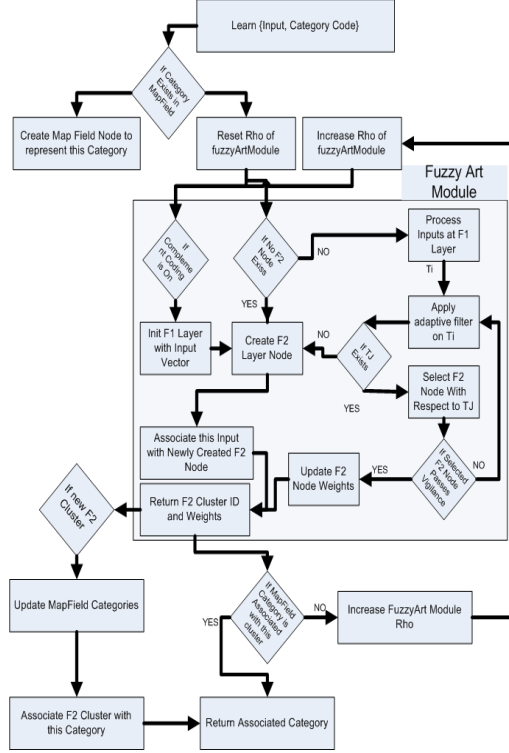

Fig. 6. Self-Scalable FuzzyArtMap Learning Dynamics

5 Experimental Results

We measure location estimation error in terms of absolute deviation of location estimate from actual location and in terms of relative deviation. Absolute deviation is measured as Mean Absolute Error (MAE), ratio of unclassified RSS vectors, ratio of miss-classified RSS vectors. Relative error is measured as ratio of estimate deviation less than a threshold value with total number of estimates. Table 1 presents training results of Fuzzy ArtMap network with and without complement coding.

Table 1. Fuzzy ArtMap Results on Training Radio Map

Clusters	ComplementCoding	MAE	Unclsfd	Missclsfd	Error ≤ 1	Error ≤ 2	Error ≤ 3
36	Yes	.066	0	.02	.02	.02	0
167	No	.018	11	.006	.006	.006	0

In parallel to Fuzzy ArtMap based location system we implemented two off line training based location systems, using feed forward network with back propagation training algorithm and learning vector quantization training algorithm, in order to evaluate relative location estimation performance. We used exactly same data to train and test all three networks. Table 2 presents comparative results of three classifiers during training.

Table 2. Comparative Results on Training Radio Map

Classifier	Unclassified	MAE	Error \leq 1	Error \leq 2	Error \leq 3
Fuzzy ArtMap-CC	0	0.06	0.02	0.02	0
Fuzzy ArtMap-No CC	11	0.02	0.005	0.005	0
MLP	0	1.03	0.25	0.21	0.09
LVQ	0	2.60	0.45	0.31	0.20

We collected different set of data, to test all three classifiers estimation performance, on a different day and time than training data. Table 3 presents comparative testing results of three classifiers.

Table 3. Comparative Results on Testing Radio Map

Classifier	Unclassified	Misclassified	MAE	Error \leq 1	Error \leq 2	Error \leq 3
FuzzyArtMap- CC	0	1.06	0.26	0.25	0.18	0.08
FuzzyArtMap-No CC	389	0.22	0.64	0.21	0.14	0.04
MLP	0	0.29	1.03	0.25	0.21	0.09
LVQ	0	0.56	2.60	0.45	0.31	0.20

6 Conclusions and Results Analysis

We employed a Self scalable Fuzzy ArtMap neural network for RSS based location system. Location estimation performance is compared with two other neural network models i) feed forward network ii) LVQ network. On the basis of results we conclude that Fuzzy ArtMaps provides superior estimation accuracy. In addition to that, our approach incorporates novel features in location systems that can not be realized using previous approaches 1) Rapid system development 2) Flexible and dynamic extension of system 3) Privacy sensitive location systems and 4) Stable estimation performance.

References

1. Moore, B (1988). "ART and pattern clustering". In Proceedings of the 1988 connectionist models summer school (pp. 174-183).
2. Carpenter, G. A., Grossberg, S., and Rosen, D. B. "Fuzzy ART: Fast stable learning and categorization of analog patterns by an adaptive resonance system", *Neural Networks*, Vol. 4, pp. 759-771, 1991a.
3. Carpenter, G.A., Grossberg, S., Reynolds, J.H., "ARTMAP: Supervised real-time learning and classification of nonstationary data by a self-organizing neural network", *Neural Networks* 4, 565-588
4. Carpenter, G.A., Grossberg, et al, "Fuzzy ARTMAP: A neural network architecture for incremental supervised learning of analog multidimensional maps", *IEEE Transactions on Neural Networks*, 3, 698-713
5. M. Teresa Serrano-Gotarredona , Bernabe Linares-Berranco, Andreas, G. Andreaou, "Adaptive resonance theory microchips-Circuit Design Techniques", Springer; 1 edition (May 5, 2005)
6. P. Bahl, et al. "RADAR: An in-building RF-based user location and tracking system." In *IEEE INFOCOM 2000*, pages 775-784, March 2000
7. R. Want and B. Schilit, "Expanding the horizons of location-aware computing", *IEEE Computer*, 34(8):31-34, August 2001.
8. Cynthia et al, "Challenges in Location-Aware Computing" Published by IEEE Com-Soc 1536-1268/03/ 2003 IEEE
9. K. Pehlavan et al, "Indoor Geolocation Science and Technology", *IEEE Communications Magazine*, 2002
10. Andrew et al, "Using Wireless Ethernet for Localization", 2002 IEEE/RSJ International Conference on Intelligent Robots and Systems
11. Mike Hazas et al, "Location-Aware Computing Comes of Age," *Computer*, vol. 37, no. 2, pp. 95-97, February, 2004.
12. Roy et al, "The active badge location system", *ACM Transactions on Information Systems (TOIS)* Volume 10 , Issue 1 pp: 91 - 102
13. UbiSense, "Local position system and sentient computing." <http://www.ubisense.net/>
14. Andy Ward et al, "A New Location Technique for the Active Office". *IEEE Personal Communications*, Vol. 4, No. 5, October 1997, pp. 42-47
15. N.B. Priyantha et al, "The Cricket Location-Support System," *Proc. 6th Ann. Int'l Conf. Mobile Computing and Networking*, ACM Press, New York, 2000, p. 32-43.
16. Tomoaki Ogawa, Shuichi Yoshino, and Masashi Shimizu, "Location Determination Method for Wireless Systems Based on Learning Vector Quantization", *NTT Network Innovation Laboratories*, Vol 1. No. 9. Japan
17. Asim Smailagic et al, "Location Sensing and Privacy in a Context Aware Computing Environment", *Pervasive Computing*, 2001.
18. Roberto Battiti et al, "Neural Network Model for intelligent networks: deriving the Location from signal patterns, *The First Annual Symposium on Autonomous Intelligent Networks and Systems 2002*
19. Uzair Ahmad et al, "Modular Multilayer Perceptron for WLAN Based Localization", *IEEE International Joint Conference on Neural Networks*, July 2006, Vancouver, Canada
20. CompoNet, Componentization of Neural Networks, Component Technology Open Source Project. <http://sourceforge.net/projects/componet/>